

| | | |
|--|---|-------------------------|
|  VECTREN | ENERGY DELIVERY INTERCONNECTION GUIDELINES FOR CUSTOMER-OWNED GENERATION (VEC) | Revision Number 3 |
| VEC-006 Energy Delivery Interconnection Guidelines for Customer-Owned Generation | | |



Energy Delivery Interconnection Guidelines for Customer-Owned Generation

VEC-006 Control Document Energy Delivery Interconnection Guidelines for Customer-Owned Generation

*Please refer questions about this document to the Electric Reliability
Compliance Department (812-491-5268 or 812-491-5878).*

| | | |
|---|---|-------------------------|
|  | ENERGY DELIVERY INTERCONNECTION GUIDELINES FOR CUSTOMER-OWNED GENERATION (VEC) | Revision Number 3 |
| VEC-006 Energy Delivery Interconnection Guidelines for Customer-Owned Generation | | |

ORIGINAL

Review Policy

This document shall be reviewed and revised annually or as necessary due to system changes or changes to the NERC standards. The annual review will be initiated by the Electric Reliability Compliance Department and approved by the Signatory Group. As a result of the annual review, updates to this document will be reflected by redline(s), and the new version of the document will be approved by the Signatory Group listed on the signature page(s) of this document. If no changes are required as a result of the document review process, the Signatory Group will certify an annual review has been conducted and file as evidence in the Electric Reliability Compliance Department Master files.

Approved By:

| Name | Title | Date |
|------|-------|------|
|------|-------|------|



| | | |
|---|---|-------------------|
|  Fred Frederick | <u>Manager, Electrical Asset Management</u> | <u>07-06-2011</u> |
|  Larry Rogers | <u>Manager, Substation & Transmission Engineering</u> | <u>7-6-2011</u> |
|  Jim Cox | <u>Chief Engineer, NERC Compliance</u> | <u>7-6-11</u> |
|  Jim Francis | <u>Director, Engineering & Asset Management</u> | <u>7/6/11</u> |

Table of Contents

| | | |
|----------|---|-----------|
| 1 | Introduction..... | 7 |
| 1.1 | Purpose..... | 7 |
| 1.2 | Vectren Policy on Customer-Owned Generation | 8 |
| 1.2.1 | Hot Transfer Standby Generation..... | 8 |
| 1.2.2 | Demand Reducing Generation..... | 9 |
| 1.2.3 | Net Metering..... | 9 |
| 1.3 | Requirements for Interconnection | 9 |
| 1.3.1 | Safety Issues | 10 |
| 1.3.2 | Reliability Issues..... | 11 |
| 1.3.3 | Quality of Service Issues | 12 |
| 1.3.4 | Protection Issues | 13 |
| 1.3.5 | Planning and Operations Issues | 13 |
| 1.4 | Generating System Sources | 14 |
| 1.5 | Generating System Operation..... | 14 |
| 1.5.1 | Separate System Operation..... | 15 |
| 1.5.2 | Parallel System Operation | 15 |
| 2 | Vectren Electric System Information | 17 |
| 2.1 | Voltage..... | 17 |
| 2.2 | Circuit Restoration..... | 17 |
| 2.3 | Effective Grounding | 17 |
| 3 | Vectren Electric System Integrity | 18 |
| 3.1 | General..... | 18 |
| 3.2 | Harmonic Distortion | 18 |
| 3.3 | Voltage..... | 18 |
| 4 | Generating System Operating Requirements | 20 |
| 4.1 | De-Energized Circuits..... | 20 |
| 4.2 | Operational Log | 20 |
| 4.3 | Discontinuation of Operation..... | 20 |
| 4.4 | Synchronous Generators | 21 |
| 4.5 | Generation Over 1 MW | 21 |
| 4.6 | Telemetry (i.e. telecommunications) | 21 |
| 4.7 | Communications | 21 |
| 5 | Generating System Design Requirements | 22 |
| 5.1 | Codes | 22 |
| 5.2 | Protective Devices | 22 |
| 5.3 | Effective Grounding | 23 |

| | | |
|---|---|----------------------------------|
|  VECTREN | ENERGY DELIVERY INTERCONNECTION GUIDELINES FOR CUSTOMER-OWNED GENERATION (VEC) | Revision Number 3 |
| VEC-006 Energy Delivery Interconnection Guidelines for Customer-Owned Generation | | |

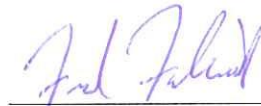
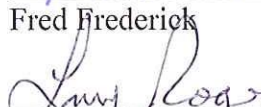
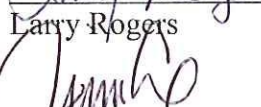
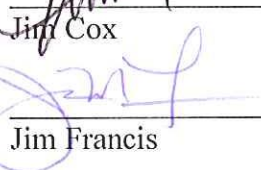
| | | |
|-----------|---|-----------|
| 5.4 | Insulation | 24 |
| 5.5 | Design Specifications | 24 |
| 5.6 | Induction Generators..... | 25 |
| 5.7 | Inverter Systems | 25 |
| 5.8 | Design Review..... | 26 |
| 6 | Metering Requirements..... | 26 |
| 6.1 | General..... | 26 |
| 6.2 | Generation 10 KW & Under..... | 27 |
| 6.3 | Generation Over 10 KW to Less Than 100 KW..... | 27 |
| 6.4 | Generation 100 KW to Less Than 1 MW | 27 |
| 6.5 | Generation 1 MW and Above..... | 28 |
| 7 | Protective Relaying Requirements..... | 29 |
| 7.1 | Protection Classes..... | 29 |
| 7.2 | Generation 10 kW & Under..... | 30 |
| 7.3 | Generation Over 10 kW to Less Than 100 kW | 30 |
| 7.4 | Generation 100 kW to Less Than 1 MW | 30 |
| 7.5 | Generation 1 MW to Less Than 10 MW | 30 |
| 7.6 | Generation Over 10 MW | 31 |
| 7.7 | Battery Power & DC Fusing..... | 31 |
| 8 | Demonstrations/Inspections of Protective Devices | 32 |
| 8.1 | General..... | 32 |
| 8.2 | Calibration | 32 |
| 8.3 | Trip Checks..... | 33 |
| 8.4 | On-Line Tests | 34 |
| 9 | Periodic Demonstrations/Inspections of Protective Devices..... | 37 |
| 9.1 | Maintenance..... | 37 |
| 9.2 | Annual Demonstrations/Inspections..... | 37 |
| 9.3 | Three-Year Demonstrations/Inspections | 38 |
| 9.4 | Design Changes After Commercial Operation | 39 |
| 10 | Figures..... | 40 |
| 10.1 | Relaying and Metering 10 kW & Under..... | 40 |
| 10.2 | Relaying and Metering Over 10 kW to Less Than 100 kW | 41 |
| 10.3 | Relaying and Metering From 100 kW to Less Than 1 MW | 42 |
| 10.4 | Relaying and Metering From 1 MW to Less Than 10 MW..... | 43 |
| 10.5 | Hot Transfer, Standby, and Demand Reducing Generation | 44 |
| 10.6 | DC Fusing..... | 45 |

| | | |
|--|---|-------------------------|
|  VECTREN | ENERGY DELIVERY INTERCONNECTION GUIDELINES FOR CUSTOMER-OWNED GENERATION (VEC) | Revision Number 3 |
| VEC-006 Energy Delivery Interconnection Guidelines for Customer-Owned Generation | | |

11 Appendix 1 46

12 Appendix 2..... 47

13 Cross References 48

| | | |
|---|---|----------------------------------|
|  | ENERGY DELIVERY INTERCONNECTION GUIDELINES FOR CUSTOMER-OWNED GENERATION (VEC) | Revision Number 3 |
| VEC-006 Energy Delivery Interconnection Guidelines for Customer-Owned Generation | | |

Revision Table

| Revision Number | Revision Date | Effective Date | Revised By | Summary of Changes |
|------------------------|----------------------|-----------------------|-------------------|--|
| 0 | 05/08/08 | 05/08/08 | R. Tabor | Revised document in new format |
| 1 | 03/10/09 | 03/31/09 | R. Tabor | <ul style="list-style-type: none"> ▪ Updated Annual Review Table ▪ Standardized document formatting. |
| 2 | 05/19/10 | 06/28/10 | M. Rose | <ul style="list-style-type: none"> ▪ Annual Review. See Redline. |
| 3 | 06/01/11 | 07/06/11 | R. Collins | <ul style="list-style-type: none"> ▪ Made content changes based on annual or self-certification review. See redline(s) and summary of document changes. |

| | | |
|---|---|--------------------------------|
|  | ENERGY DELIVERY INTERCONNECTION GUIDELINES FOR CUSTOMER-OWNED GENERATION (VEC) | Revision Number 3 |
| VEC-006 Energy Delivery Interconnection Guidelines for Customer-Owned Generation | | |

1 Introduction

1.1 Purpose

The purpose of these guidelines is to provide preliminary technical information to parties who are interested in investigating the potential of interconnecting customer-owned generation to the Vectren electric system or upgrading existing generating facilities and any new facilities.

Vectren shall make documentation of these requirements available to the users of the transmission system, the Regional Entity, Regional Reliability Organization and NERC on request within five business days.

For purpose of simplicity, the term "Producer" is used in these guidelines to refer to the owner of the customer-owned generating system.

These guidelines are recommendations only and do not relieve the Producer from independently evaluating the customer-owned generating system's performance, compliance and safety. It shall be the Producer's sole responsibility to evaluate and ensure safety with respect to Producer facilities and employees. Vectren assumes no liability or responsibility with respect to the accuracy or completeness of these guideline recommendations contained herein.

These guidelines state general Vectren recommendations to ensure that the interconnection of customer-owned generation, to the Vectren electric system, shall not adversely impact reliability or quality of electric service to Vectren or its customers.

Producer and Vectren personnel shall use these guidelines when planning installations or upgrades for customer-owned generation. Information contained in these guidelines will be useful in understanding Vectren requirements for proper design, analysis and coordination in the pursuit of a comprehensive, interconnection feasibility study. It is emphasized that these requirements are general and may not cover all details in specific cases. The Producer should discuss project plans with Vectren before purchasing or installing equipment.

The generating system shall not impose an economic burden to Vectren or its customers. Therefore, the Producer is responsible for paying all interconnection costs. These guidelines identify certain costs to the

| | | |
|---|---|----------------------------------|
|  | ENERGY DELIVERY INTERCONNECTION GUIDELINES FOR CUSTOMER-OWNED GENERATION (VEC) | Revision Number 3 |
| VEC-006 Energy Delivery Interconnection Guidelines for Customer-Owned Generation | | |

Producer which include such things as: design and installation, metering and communications, protective and safety devices, power-factor-correction, power quality and reliability mitigation, power system studies, reviewing submitted plans, inspection and maintenance services, modifications to the existing Vectren electric system, administrative and insurance costs; however, limited to only those costs actually incurred by Vectren. These guidelines do not address Federal Energy Regulatory Commission (FERC) or state regulatory requirements, transmission access or other commercial terms and conditions to transport or sell energy.

1.2 Vectren Policy on Customer-Owned Generation

It is Vectren policy to permit any Producer to operate generating equipment in parallel with the Vectren electric system whenever this can be done without adverse effects to Vectren personnel and equipment, or its customers. The operation of generating equipment in parallel with the Vectren electric system is allowed only after Vectren written approval is provided to the Producer. Protective devices, such as relays, circuit breakers, etc., specified by Vectren, must be installed at any location where a Producer desires to operate generation in parallel with the Vectren electric system. The purpose of these devices is to promptly disconnect the Producer's generating system from the Vectren electric system whenever electrical faults or abnormal operating conditions occur.

1.2.1 Hot Transfer Standby Generation

Hot Transfer Standby Generation is when the Producer's generation can be interconnected to the Vectren electric system on a short-term basis. The purpose of this type of interconnected system is to transfer load from the Vectren electric system to the Producer's generating system and back again without an interruption. The duration of the interconnection is not to exceed ten minutes. This type of interconnection is often referred to as a "closed transition." The closed transition is used exclusively to prevent interruption of the Producer's critical loads. A transfer of power from the Producer's generating system to the Vectren electric system may be prevented by a sensitive directional power relay, shown in Figure 10.5 as Device 32.

| | | |
|---|---|--------------------------------|
|  | ENERGY DELIVERY INTERCONNECTION GUIDELINES FOR CUSTOMER-OWNED GENERATION (VEC) | Revision Number 3 |
| VEC-006 Energy Delivery Interconnection Guidelines for Customer-Owned Generation | | |

1.2.2 Demand Reducing Generation

Demand Reducing Generation is when the customer-owned generator is interconnected to the Vectren electric system: however, no power is intentionally transferred to or purchased by Vectren. The local demand is reduced, i.e. "peak shaving." Since the Producer's rate may not permit peak shaving, the Vectren Field Sales and/or Rate Departments shall be contacted for initial approval. If approved, the interconnection requirements shall be based on the generator rating. Refer to Sections 5.1 through 5.6.

1.2.3 Net Metering

This service is available to Vectren Electric Customers as described in Rider NM, Net Metering Rider within Vectren's Tariff for Electric Service. Customers must also meet the Generator System Requirements and Interconnection Requirements as specified in Indiana Administrative Code (170 IAC 4-4.3) and in the Vectren Net Metering Rider. Total participation on this service will be limited and shall be available on a first come, first served basis.

1.3 Requirements for Interconnection

The operation of a customer-owned generator, interconnected to the Vectren electric system, presents several issues of concern for the Vectren electric system. These concerns include: safety, reliability, quality of service, protection planning and operations problems. Vectren must maintain the integrity of its system to ensure a reliable supply of electricity to its customers. Therefore, any interconnected generating system must include equipment dedicated to protecting the Vectren electric system from problems which may originate within the interconnected generating system.

For generators connecting to the electric distribution system, if the existing distribution transformer is unacceptable, the generator owner must install a dedicated transformer for the generator. Any generator over 50kW, except an inverter connected generator, shall be connected to the Vectren system using a dedicated generator step-up transformer whenever possible.

For interconnection to the Vectren electric transmission system, the Producer is also required to comply with Vectren's [VEC-007 Requirements for Transmission or End-User Facilities](#)

| | | |
|---|---|--------------------------------|
|  | ENERGY DELIVERY INTERCONNECTION GUIDELINES FOR CUSTOMER-OWNED GENERATION (VEC) | Revision Number 3 |
| VEC-006 Energy Delivery Interconnection Guidelines for Customer-Owned Generation | | |

Interconnection to the Vectren Electric Transmission System. This document provides general requirements for the transmission facilities needed to interconnect the Producer’s generating facility to the Vectren electric transmission system. The Producer must also comply with any RFC, NERC, FERC or other applicable agency standards and requirements.

Also, since Vectren is a member of the Midwest ISO (MISO), which performs as the Transmission Provider, Planning Authority and Reliability Coordinator, the Producer must first file a request with MISO for an interconnection to the Vectren electric transmission system. The MISO will notify transmission owners that may be impacted by the generation addition and perform coordinated joint studies to appraise the impact of the generation addition and identify any upgrade requirements. In addition, these studies will address plans to achieve the required system performance as required throughout the planning horizon. The Producer may be responsible for some or all of these costs, including the costs to perform the studies.

The Producer is also required to notify Vectren and MISO of any proposed modifications to facilities that could impact the operation and maintenance of the Producer’s facilities or that could impact the reliability of the interconnected electric system.

These guidelines are for informational purposes only and do not relieve the Producer from requirements to comply with the National Electrical Safety Code, the National Electrical Code, and all relevant IEEE Standards, including IEEE 1547 - IEEE Standard for Interconnecting Distributed Resources with Electric Power Systems.

1.3.1 Safety Issues

Safety concerns focus first on isolating the interconnected generator from the Vectren electric system when a Vectren electric system line is opened. Isolation shall be both automatic and manual. When a Vectren circuit is damaged, such as when a power line falls to the ground during a storm, a hazard to the public exists until all power sources are isolated from that circuit. Because speed is critical, this type of isolation must be automatic. The method for accomplishing automatic isolation may vary depending on size, electrical characteristics and other factors of both the interconnected generating system and the Vectren electric system. A lockable, manually operated switch or disconnect with visible breaks between the Vectren electric system and all customer-owned energy sources is required. This

| | | |
|---|---|----------------------------------|
|  | ENERGY DELIVERY INTERCONNECTION GUIDELINES FOR CUSTOMER-OWNED GENERATION (VEC) | Revision Number 3 |
| VEC-006 Energy Delivery Interconnection Guidelines for Customer-Owned Generation | | |

switch or disconnect shall be subject to Vectren lock-out and tag-out procedures.

Another concern with isolating an interconnected generator is self-excitation of the generator. When an induction generator is isolated from the Vectren electric system, because of a downed line or a breaker opening the line, the generator will usually shut down. However, if there is sufficient capacitance in nearby circuits, e.g., power-factor-correcting capacitors, the induction generator can continue to operate independently of the Vectren electric system. The power produced by the self-excited induction generator will not be regulated by the Vectren electric system, and the customer's electricity-using equipment can be damaged. More importantly, an isolated self-excited induction generator that re-energizes a downed transmission or distribution line can endanger Vectren employees and the public. Voltage and frequency relays and automatic disconnect circuit breakers shall be used to protect the customer's equipment, Vectren employees, and the public.

The third safety concern is preventing the isolated generator from energizing a de-energized Vectren electric system circuit. Energizing a de-energized circuit can endanger the public, rescue workers, Vectren employees and others who may have determined that the circuit is de-energized and were in contact with the circuit. In this situation, energizing a de-energized circuit shall be blocked for all automatic and manual isolation schemes.

1.3.2 Reliability Issues

Reliability of electric service should be as important an issue to the Producer as to Vectren. The Producer is also a Vectren customer and desires reliable service. Therefore, the Producer shall ensure that the interconnected generating system does not impact the reliability of electric service by causing unnecessary interruptions. This consideration may influence the equipment protection scheme designs, discussed later. Vectren may require a greater margin of protection for its system, in order to maintain service to other customers. Thus, protective relay settings shall be coordinated so that the safety and reliability of electric service are not compromised.

| | | |
|---|---|--------------------------------|
|  | ENERGY DELIVERY INTERCONNECTION GUIDELINES FOR CUSTOMER-OWNED GENERATION (VEC) | Revision Number 3 |
| VEC-006 Energy Delivery Interconnection Guidelines for Customer-Owned Generation | | |

Another consideration, which impacts Vectren electric system reliability, is the location of the interconnected generating system on the Vectren electric system. If the interconnection location is at a transmission level, then interruptions of service have a greater impact than when located at a distribution level. Vectren may require even more stringent protection requirements for an interconnected generating system located at a transmission level to protect other customers “downstream” of the generator.

A final consideration is the generator size compared to the interconnected generating system load and the load on the Vectren electric system line. If the interconnected generator output capacity is much smaller than the interconnected generating system load, the impact of disturbances created by the generator may not be electrically significant to the rest of the generating system and the Vectren electric system. The more on-site load, the more damping there will be to minimize effects of generator disturbances. However, as generator output capacity approaches or exceeds the generating system load, the impact of generator disturbances may become more significant. This will result in more stringent protective requirements.

1.3.3 Quality of Service Issues

Vectren customers expect electric service to meet certain tolerances of voltage, frequency, and duration so that their loads function efficiently and reliably and are not damaged by normal operating conditions. Power supplied to the Vectren electric system by an interconnected generating system shall also be within certain tolerances so that the overall power quality of the Vectren electric system remains satisfactory.

One problem may be lagging or leading power factor (pf). Capacitors can be used to correct lagging power factor. If too much capacitance is used, the power factor will change from lagging to leading. Undesirable power factor is likely with induction generators and with some types of dc-to-ac inverters. The results of undesirable power factor can be an increase in power losses, larger voltage drops in supply circuits and equipment overheating. Careful placement and control of capacitors is necessary for proper power factor management.

| | | |
|---|---|--------------------------------|
|  | ENERGY DELIVERY INTERCONNECTION GUIDELINES FOR CUSTOMER-OWNED GENERATION (VEC) | Revision Number 3 |
| VEC-006 Energy Delivery Interconnection Guidelines for Customer-Owned Generation | | |

Another problem may be harmonic currents. Harmonic currents occur at frequencies other than the desired 60 Hz of the power signal. When transmitted along transmission or distribution lines, these harmonics distort the desired voltage and current waveforms. Harmonic currents can cause improper operation of ground-fault and other protective relays, carrier communication systems, motors, sensitive electronic equipment and computers; they can also cause capacitor overloading. Sources of these harmonic currents can include solid-state switching devices: dc-to-ac inverters, variable-speed drives, ac-to-dc-to-ac converters, etc., generator winding faults and generator pitched for stand-alone operation.

Another problem may be voltage control in areas near the interconnected generating system. Voltage variations “flicker” can occur when there are sudden changes of current flowing in a circuit. Voltage flicker can be caused by generation suddenly coming on or off line or by starting generators or motors. Voltage flicker can cause misoperation of sensitive equipment or visual irritation. Resonant overvoltages can typically be two to three times normal voltage for long durations. Voltages of this level can damage Vectren and customer-owned equipment.

1.3.4 Protection Issues

Both the Producer and Vectren must protect their respective personnel and systems from injury or damage, which may be caused by the malfunction of a customer-owned generator. This protection often utilizes automatic equipment to detect and isolate faulted sections of a system so that the remainder of the system can continue to operate without interruption. This equipment also attempts to protect the system from damage to improve reliability and quality of electric service to the interconnected generating system, and to the Vectren electric system and its customers.

1.3.5 Planning and Operations Issues

Where customer-owned generators are present, several areas of Vectren electric system planning can be affected for two reasons: first, is that a dispersed generator exists, as opposed to centralized generators, and second, is the assumption of unidirectional power flow from the Vectren electric system to customers may no longer be valid.

| | | |
|---|---|--------------------------------|
|  | ENERGY DELIVERY INTERCONNECTION GUIDELINES FOR CUSTOMER-OWNED GENERATION (VEC) | Revision Number 3 |
| VEC-006 Energy Delivery Interconnection Guidelines for Customer-Owned Generation | | |

Vectren will need to account for deviations from expected load surveys and load factors caused by dispersed generation. Both of these are affected by dispersed generation. Load surveys are done to determine electrical demands Vectren must meet for the present and for the future. These surveys form the foundation of system planning. Load factors reflect the utilization of Vectren electric system equipment, the ratio of average usage to the peak usage. The Producer shall be required to pay for any increased costs resulting from changes in Vectren operating procedures.

Operations, for both the interconnected, generating system and the Vectren electric system, is effected by the customer-owned generator. The impact on Vectren electric system operations may include extra records and communications required to work safely on circuits with dispersed generation and increased time to do repair work. If the customer-owned generator is very large, Vectren may choose to include the generator in its dispatch of generating units and retain some control over the generator operation. The control system may use telemetering. Also, very large generators can impact the Vectren electric system stability, the ability of the system to stay synchronized after any disturbance, and Vectren may require even more stringent protection requirements or special equipment to maintain stability margins.

1.4 Generating System Sources

The Producer may elect to use any of a variety of energy sources including: solar, wind, hydro or other types of sources, in addition to conventional fossil fuels. For interconnection to the Vectren electric system, the generating system shall generate 60 Hz sinusoidal alternating current at a Vectren standard voltage and phase rotation.

1.5 Generating System Operation

The Producer may elect to operate the generator as a separate system with the capability of non-parallel load transfer between the two independent systems or in parallel with the Vectren electric system. These two methods of system operation are discussed below.

| | | |
|---|---|--------------------------------|
|  | ENERGY DELIVERY INTERCONNECTION GUIDELINES FOR CUSTOMER-OWNED GENERATION (VEC) | Revision Number 3 |
| VEC-006 Energy Delivery Interconnection Guidelines for Customer-Owned Generation | | |

1.5.1 Separate System Operation

A separate system is a system to which there is no possibility of interconnecting the Producer’s generating system in parallel with the Vectren electric system. Un-interruptible Power Supply Systems (UPS) may not meet the separate system operating criteria and should not be considered unless they are designed for and meet the separate system operating criteria.

For this design to be practical, the Producer must be capable of transferring load in an “open transition,” or non-parallel mode, between the Producer’s generating system and the Vectren electric system. This can be accomplished by either an electrical or mechanical “fail safe” interlocked switching arrangement, which prevents operation of both switches in the closed position simultaneously.

If the Producer has a separate system, Vectren shall require verification that a transfer scheme exists and meets non-parallel mode requirements. Verification will be accomplished by the approval of drawings by Vectren in writing and, if Vectren so chooses, by field inspection of the transfer scheme. Vectren shall not be responsible for approving the Producer’s generating system equipment and assumes no responsibility for its design, operation or effects on the Producer’s loads.

1.5.2 Parallel System Operation

A parallel system is a system to which the Producer’s generating system can be connected to the Vectren electric system. A transfer of power between the two systems is a direct and often desired result.

The Vectren electric system is subject to a variety of natural and man-made hazards, which can cause system disturbances. Electrical disturbances that can result from these hazards are typically fault conditions: short circuits, grounded conductors and broken conductors. These fault conditions require that the damaged equipment is de-energized immediately due to the hazards they may pose to the public and to the operation of the Vectren electric system. A parallel system operated generator shall have adequate protective devices installed, which will detect fault conditions on the Vectren electric system and will operate to disconnect the generator. The protective devices must

| | | |
|---|---|--------------------------------|
|  | ENERGY DELIVERY INTERCONNECTION GUIDELINES FOR CUSTOMER-OWNED GENERATION (VEC) | Revision Number 3 |
| VEC-006 Energy Delivery Interconnection Guidelines for Customer-Owned Generation | | |

be properly designed and sized appropriately by the Producer to withstand the fault levels and voltage surges that may occur.

Parallel system operated generation can cause a condition known as "accidental isolation" where a portion of the Vectren electric system load becomes isolated from the Vectren electric system source and remains interconnected to the paralleled generator. In this condition, the isolated system can continue to operate independently from the Vectren electric system and develop abnormal voltage or frequency.

Protective device requirements are discussed in the following sections and are intended to disconnect the paralleled generator when Vectren electric system disturbances occur. The scope of protective equipment is, in part, based on the size of the generator. General and specific requirements for parallel generation installations of various generator sizes are discussed in the following sections.

In order to properly parallel the Producer's equipment with the Vectren electric system, the Producer must incorporate automatic synchronizing equipment that can smoothly interconnect the Producer's generating equipment with the Vectren electric system.

Improper synchronizing can cause significant damage to the Producer's equipment, and possibly Vectren and other customers' equipment. The Producer will be held liable for any damage caused by improper synchronizing of Producer's equipment.

| | | |
|---|---|--------------------------------|
|  | ENERGY DELIVERY INTERCONNECTION GUIDELINES FOR CUSTOMER-OWNED GENERATION (VEC) | Revision Number 3 |
| VEC-006 Energy Delivery Interconnection Guidelines for Customer-Owned Generation | | |

2 Vectren Electric System Information

2.1 Voltage

Vectren transmission line voltages are 69 kV, 138 and 345 kV. Common primary distribution line voltages are 12.47 kV and 4.16 kV, depending on the geographic area. These distribution circuits are effectively grounded and are normally used for four-wire distribution phase-to-neutral and phase-to-phase connected loads. The Producer should contact Vectren for information on specific circuit voltages available to the Producer's generating system.

Voltages are normally held within 95 to 105 percent of nominal voltage. Under certain conditions the voltage on transmission system may drop to 90 percent. However, the Producer should design its system to protect against low or high voltage conditions in excess of these values that may occur under abnormal conditions.

2.2 Circuit Restoration

Because most short circuits on overhead lines are of a temporary nature, it is Vectren's practice to reclose circuit breakers on transmission and distribution lines after they have automatically tripped. Protective relays, specified by Vectren for parallel generation interfaces, are intended to disconnect the generator from faulted or isolated lines before reclosing occurs. On-site relaying is not always adequate to ensure separation when the Producer's generator is capable of supplying most or all of the line or line segment load. It is the responsibility of the Producer to install necessary equipment to ensure a proper disconnection exists before reclosing occurs. Vectren costs for installing, maintaining, and/or rearranging such equipment shall be borne by the Producer.

2.3 Effective Grounding

Vectren maintains effective grounding on its distribution system. A general definition for an effectively grounded system is where the ratio of zero-sequence reactance to positive-sequence reactance is less than or equal to three ($X_0/X_1 \leq 3.0$), and the ratio of zero-sequence resistance to positive-sequence reactance is less than or equal to one ($R_0/X_1 \leq 1.0$), for any condition of operation and for any amount of generator capacity.

Vectren uses effective grounding to limit the range of voltage rise on unfaulted phases during fault conditions and to provide a source of ground current to operate protective relays. This is done to protect customer phase-to-ground connected loads.

| | | |
|---|---|--------------------------------|
|  | ENERGY DELIVERY INTERCONNECTION GUIDELINES FOR CUSTOMER-OWNED GENERATION (VEC) | Revision Number 3 |
| VEC-006 Energy Delivery Interconnection Guidelines for Customer-Owned Generation | | |

3 Vectren Electric System Integrity

3.1 General

Interconnection of the Producer's generating equipment to the Vectren electric system shall not cause any reduction in the quality of service provided to Vectren customers. No abnormal voltages, frequencies, or interruptions shall be permitted. If steady state or transient voltage complaints result from operation of Producer generation, such generating equipment shall be disconnected until the problem is resolved at the Producer's expense.

3.2 Harmonic Distortion

Voltage and current harmonic distortion on a power system, from any source, shall be kept to a minimum. Periodically, Current Total Harmonic Distortion (I_{THD}), generated by the Producer's generating system, and Voltage Total Harmonic Distortion (V_{THD}), developed by the Producer's generating system, will be measured by Vectren employees at the Producer's point of common coupling, the Vectren metering point. Under no circumstances, shall V_{THD} of the voltage waveform or I_{THD} of the current waveform be allowed to exceed levels established in **IEEE Std. 519**. If a Producer's generating system is found to be interfering with other customers, Producers, Vectren, or public communications equipment, the Producer shall be required to install filtering, or other corrective measures, to bring the harmonic output of the generating system to an acceptable level and shall be resolved at the Producer's expense.

3.3 Voltage

Operation of the Producer's generator shall not adversely affect voltage stability on the Vectren electric system. Adequate voltage control shall be provided, by the Producer, to minimize voltage regulation on the Vectren electric system caused by changing generator loading conditions. Automatic power factor or reactive power (VAr) controllers shall be provided for installations utilizing synchronous generators.

| | | |
|---|---|--------------------------------|
|  | ENERGY DELIVERY INTERCONNECTION GUIDELINES FOR CUSTOMER-OWNED GENERATION (VEC) | Revision Number 3 |
| VEC-006 Energy Delivery Interconnection Guidelines for Customer-Owned Generation | | |

All generator installations over 10 kW shall maintain at least a power factor of 0.9 leading (VARs going into the machine) over an operating range of 25% to 100% of the generators rating. Inverter connected and synchronous machines shall maintain a power factor of 1.0 at their terminals unless otherwise directed by Vectren. All synchronous machines shall be capable of operating at between 0.9 leading to 0.9 lagging power factor.

For synchronous generators, sufficient generator reactive power capability shall be provided to withstand normal operating voltage changes on the Vectren electric system. The generator voltage-VAr schedule, voltage regulator and transformer ratio settings shall be jointly determined by Vectren and the Producer to ensure proper coordination of voltages and regulator action.

No synchronous generator shall regulate the voltage at its terminals on the distribution system unless agreed to by Vectren. All synchronous generators on the distribution system shall be operated in power factor control mode unless a study determines voltage control is advantageous and will not cause problems with regulators and tap changers in Vectren's system.

All induction generators shall match speed to within 5% of synchronous speed before their breakers are closed. Across the line starting and electrically accelerating of induction generators, without first accelerating the machine to within 5% of synchronous speed using the prime mover before closing the breaker shall be permitted only when agreed to by Vectren.

In cases where starting or load changing on induction generators will have an adverse impact on Vectren electric system voltage, step-switched capacitors or other techniques may be required, at the Producer's expense, to bring voltage changes to synchronous speed before connecting to the Vectren electric system. In some cases, a closer speed match will be required.

| | | |
|---|---|--------------------------------|
|  | ENERGY DELIVERY INTERCONNECTION GUIDELINES FOR CUSTOMER-OWNED GENERATION (VEC) | Revision Number 3 |
| VEC-006 Energy Delivery Interconnection Guidelines for Customer-Owned Generation | | |

4 Generating System Operating Requirements

4.1 De-Energized Circuits

The Producer shall not be permitted to energize a de-energized Vectren circuit under any circumstances without prior Vectren permission. Failure to observe this requirement is cause for immediate and permanent disconnection of the generating system. In addition, the Producer shall be held responsible for all damages and injuries resulting from such actions.

4.2 Operational Log

The Producer shall maintain an operational log at each generating system location over 20 kW indicating changes in operating status, available or unavailable, maintenance outages, trip indications or other unusual conditions found upon inspection. For generators that are "block-loaded" to a specific kW level, changes in this setting shall also be logged. The operational log shall be available for inspection upon request by Vectren.

4.3 Discontinuation of Operation

The Producer shall discontinue paralleled system operation when requested by Vectren for the following reasons:

1. To facilitate maintenance, testing or repair of the Vectren electric system.
2. During any emergency condition.
3. When the Producer's generating equipment is interfering with other customers connected to the Vectren electric system.
4. When a Vectren inspection of the Producer's generating system equipment reveals a condition hazardous to the Vectren electric system or a lack of scheduled maintenance or maintenance records for equipment necessary to protect the Vectren electric system.

| | | |
|---|---|--------------------------------|
|  | ENERGY DELIVERY INTERCONNECTION GUIDELINES FOR CUSTOMER-OWNED GENERATION (VEC) | Revision Number 3 |
| VEC-006 Energy Delivery Interconnection Guidelines for Customer-Owned Generation | | |

4.4 Synchronous Generators

Producers with synchronous generators greater than 10 kW shall provide the following:

1. Voice communication, at all times, to the generating facility via communication circuits.
2. Name and telephone number of the designated operating agent. Designated operating agent and other operating personnel shall be familiar with Vectren line clearance and operating procedures.
3. Notification to Vectren’s designated operating center prior to bringing the generator on line and time of interconnection.
4. Notification to Vectren’s designated operating center at the time the generator is disconnected from the Vectren electric system.
5. A droop setting on the governor of 5% is required.
6. All machines shall be capable of operating at between 0.9 leading to 0.9 lagging power factor.

4.5 Generation Over 1 MW

All generating systems in this category, induction, inverter, or synchronous, must comply with the requirements of Section 4.4. The generating system in this category shall provide telemetering to Vectren’s designated operating center (and MISO if applicable) for continuous kilowatt, kilovar and hourly generation values in kilowatt-hours.

4.6 Telemetry (i.e. telecommunications)

The design, purchase, installation, testing, maintenance, and replacement of telemetry equipment and circuits from the Producer’s generating system to Vectren’s designated operating center (and MISO if applicable) shall be the responsibility of the Producer and must be approved by Vectren to insure correct operation and system compatibility.

4.7 Communications

Normal Operations - At Vectren’s request, the Producer may be required to provide a dedicated voice communication circuit to the Vectren Transmission System Operations (TSO). Such a dedicated voice communication circuit would originate from the Producer’s office

| | | |
|---|---|--------------------------------|
|  | ENERGY DELIVERY INTERCONNECTION GUIDELINES FOR CUSTOMER-OWNED GENERATION (VEC) | Revision Number 3 |
| VEC-006 Energy Delivery Interconnection Guidelines for Customer-Owned Generation | | |

staffed 24 hours a day and would be typically required for generation facility synchronization and operation within Vectren’s Control Area. All other normal voice communication concerning facility operations shall be conducted through the public telephone network to the TSO phone number(s) issued by Vectren.

Emergency Operations - Voice communications in the event of a transmission system or capacity emergency shall use the dedicated voice circuits, or public telephone network and phone number(s) designated for emergency use.

In the event of an electric system or capacity emergency, the Producer may be notified by Vectren. Specific instructions may also be given regarding the operation of the Producer’s unit(s) depending on the nature of the emergency. These instructions may consist of voltage schedule changes, real and/or reactive dispatch changes, or instructions to shut down or start-up the Producer’s unit(s). It is the Producer’s responsibility to ensure that the unit operators follow all instructions given by Vectren during system emergencies.

5 Generating System Design Requirements

5.1 Codes

Producer installations shall meet Indiana Utility Regulatory Commission rules for customer-owned generation systems and all applicable national, state and local construction and safety codes including the National Electrical Safety Code, the National Electrical Code, and all relevant IEEE Standards.

5.2 Protective Devices

Protective devices: relays, circuit breakers, etc. for the protection of Vectren’s system, metering equipment and synchronizing equipment shall be provided by the Producer as required by Vectren. Protective devices differ with the size of the generating system. Producer shall ensure that the equipment ratings are sufficient to operate under normal and contingency states. Consideration must be given to maximum continuous operating voltage, continuous current ratings, over current duty ratings. Refer to Section 7 for information concerning protective relaying requirements.

| | | |
|---|---|--------------------------------|
|  | ENERGY DELIVERY INTERCONNECTION GUIDELINES FOR CUSTOMER-OWNED GENERATION (VEC) | Revision Number 3 |
| VEC-006 Energy Delivery Interconnection Guidelines for Customer-Owned Generation | | |

A manual-disconnecting device, capable of interrupting the generator and/or rated load current, shall be provided by the Producer and approved by Vectren. The form of this device will vary with the service voltage and capacity. This disconnecting device shall be accessible to Vectren personnel at all times. The device shall be of a design that can be locked open for line clearances.

If it is determined that ground fault, or other line protection is required on the high voltage side of the transformer, a 3-phase interrupting device may need to be installed on the transformer high-voltage side. If needed, this device will be supplied and installed by Vectren at the expense of the generator owner.

The Producer will provide surge protection for its equipment. This surge protection equipment is to be coordinated with Vectren’s equipment to ensure protection against voltage surges on both the Producer’s and Vectren’s systems.

5.3 Effective Grounding

All systems shall maintain effective grounding. Refer to Section 2.3. Systems over 100 kW shall have an X_0/X_1 ratio within the range of 2.5 to 3.0 during islanding, loss of Vectren source conditions. For systems over 1 MW, this is easily accomplished with a delta-delta step-up transformer and a grounding bank on the distribution feeder side. The grounding bank is sized so that its reactance divided by the sum of the subtransient reactance of the generator and the reactance of the step-up transformer is between 2.5 and 3.0. If a grounding resistor is used, it shall restrain voltage on unfaulted phases to 120% or less. The grounding bank shall have an adequate continuous rating to withstand the range of system unbalance permitted by existing regulations.

A grounded wye-grounded wye step-up transformer is only acceptable for systems less than 1 MW. For any step-up transformer configuration, the ratio of the sum of zero-sequence reactances of the step-up transformer, generator subtransient and any generator or step-up transformer neutral grounding and grounding bank shall be between 2.5 and 3.0 during islanding conditions. If a generator neutral reactor is used, it shall be sized in accordance with this formula. If a generator neutral resistor is used, it shall be sized to limit the overvoltage on unfaulted phases to 120% of nominal, during single line-to-ground faults.

| | | |
|---|---|----------------------------------|
|  | ENERGY DELIVERY INTERCONNECTION GUIDELINES FOR CUSTOMER-OWNED GENERATION (VEC) | Revision Number 3 |
| VEC-006 Energy Delivery Interconnection Guidelines for Customer-Owned Generation | | |

The reactor or resistor will limit generator damage due to single line-to-ground faults as well as minimize the affect on Vectren grounding. The reactor, resistor, or grounding transformer shall be capable of carrying at least 20% of generator rated current on a continuous basis. Since many generators create excessive harmonics if their neutral is grounded, care must be exercised in generator selection or a grounding transformer should used. If the generator cannot tolerate severe phase current unbalance, a grounding transformer is recommended.

5.4 Insulation

The insulation of the Producer’s equipment shall be of suitable design to ensure that all equipment is properly protected against lightning, switching, and fundamental-frequency overvoltages and coordinated with Vectren’s system.

5.5 Design Specifications

The Producer shall submit detailed design specifications and engineering information, usually 180 days prior to interconnection. The design specifications shall include the following:

1. The service voltage and location of the point of interconnection.
2. An electrical one-line diagram of the Producer’s generating system, beginning at the interconnection point, and the AC and DC schematics.
3. A detailed description of how and where the Producer’s load will be connected and disconnected.
4. The capacity and ownership of all equipment and circuits.
5. Capacity and interrupting ratings for all equipment and safety devices, including detailed information of all protective relaying.
6. A detailed description of any special control equipment required.
7. Sufficient information to establish all necessary rights-of-way and easements to install, operate, maintain, replace, and remove Vectren’s system.
8. Machine characteristics, ratings and other technical information specified in the Appendix 1 and 2 of this document.

| | | |
|---|---|--------------------------------|
|  | ENERGY DELIVERY INTERCONNECTION GUIDELINES FOR CUSTOMER-OWNED GENERATION (VEC) | Revision Number 3 |
| VEC-006 Energy Delivery Interconnection Guidelines for Customer-Owned Generation | | |

5.6 Induction Generators

For generation aggregating less than or equal to 10 kW capacity, Vectren will supply the VAR requirements from general system sources without a specific charge to the Producer. Installations over 10 kW capacity shall require capacitors to be installed to maintain a power factor of at least 0.9. See Section 3.3. Such capacitor installations shall be at the Producer's expense.

The self-excited induction generator can produce abnormally high voltages that can cause damage to Vectren and customer equipment. Overvoltage relays can limit the duration of such overvoltages but cannot control their magnitude. Because of these problems, the reactive power supply for large induction generators must be studied on an individual basis. In general, self-excitation problems are most likely in rural areas where the Vectren electric system capacity and load density are low. It is particularly important to contact Vectren to determine if an induction machine can be connected to an existing distribution line. Where self-excitation problems appear likely, special service arrangements will be required. In many cases, the additional expense for such special service methods will outweigh the cost savings associated with induction generators. Especially during self-excitation, effective grounding is important to restrict the range of voltage unbalance. Refer to Section 5.3.

5.7 Inverter Systems

Total harmonic distortion (THD) from the generating system will be measured at the interconnection metering point. Under no circumstances, shall V_{THD} of the voltage waveform or I_{THD} of the current waveform be allowed to exceed levels established in **IEEE Std. 519**. If a Producer's inverter system is found to be interfering with other customers, Producers, Vectren, or public communications, the Producer shall be required to install filtering or other corrective measures to bring the harmonic output of the inverter to an acceptable level, and shall be resolved at the Producer's expense.

| | | |
|---|---|--------------------------------|
|  | ENERGY DELIVERY INTERCONNECTION GUIDELINES FOR CUSTOMER-OWNED GENERATION (VEC) | Revision Number 3 |
| VEC-006 Energy Delivery Interconnection Guidelines for Customer-Owned Generation | | |

5.8 Design Review

Vectren shall review submitted plans and either accept the plans or outline specific additional functions which must be provided along with supportive data within a reasonable period of time according to existing regulating agency requirements. A rejected plan shall be modified and re-submitted for review. Vectren costs for reviewing submitted plans shall be borne by the Producer.

Vectren’s concern is to protect its system and customers from damage or hazards due to the operation of interconnected generation. To this end, Vectren’s protection requirements do not directly concern the protection of the Producer’s generator and associated equipment from short circuits, overload, equipment failures or other malfunctions caused by the Producer’s loads or equipment.

6 Metering Requirements

6.1 General

Metering installation requirements, for each interconnected generating system category, are outlined in the Vectren Electric Service Manual and in the MISO Open Access Transmission Tariff, if applicable. Unless agreed to otherwise, Vectren will furnish, install and own the meter for the registration of all electrical energy. The Producer shall provide a suitable place for the installation of the metering equipment and shall consult Vectren regarding the location of the metering equipment. The Producer shall provide Vectren employees access, at all times, to the metering installation to modify, operate, maintain and read the metering equipment.

When the Producer owns the interconnection transformer, transformer high-side metering or loss-compensated metering shall be used, as required by Vectren. When Vectren owns the interconnection transformer, transformer low-side metering with transformer loss compensation shall be utilized for power deliveries to Vectren. Vectren costs for installing, maintaining, and/or rearranging the metering equipment shall be borne by the Producer.

| | | |
|---|---|--------------------------------|
|  | ENERGY DELIVERY INTERCONNECTION GUIDELINES FOR CUSTOMER-OWNED GENERATION (VEC) | Revision Number 3 |
| VEC-006 Energy Delivery Interconnection Guidelines for Customer-Owned Generation | | |

Two metering scheme options are available for Producers who have contracted to sell power to Vectren with generating systems greater than 10 kW:

Option "A" shall be used when the Producer's load requirements are served directly by the Producer's generator. This metering option will measure the power leaving the Producer's generating system, and will measure the power entering the Producer's generating system.

Option "B" shall be used when Vectren serves the Producer's load requirements. This metering option will measure the net output of the generator, which is the gross output of the generator minus the power consumed by the power production process, station service, and will measure all other loads not associated with the power production process.

6.2 Generation 10 KW & Under

A single meter shall be applied for this category and located as shown in Figure 10.1. Installation requirements as outlined in the Vectren Electric Service Manual are applicable.

6.3 Generation Over 10 KW to Less Than 100 KW

Metering options "A" or "B" shall be applied for this category as shown in Figure 10.2. Installation requirements as outlined in the Vectren Electric Service Manual are applicable.

6.4 Generation 100 KW to Less Than 1 MW

Metering options "A" or "B" shall be applied for this category as shown in Figure 10.3. Most of these meters will require dedicated instrument transformers and installation requirements shall conform to the **Vectren Electric Service Manual**.

If the nominal voltage of the metered circuit exceeds 480 volts, a transformer type primary meter installation, using both current and voltage transformers, is required, regardless of the load current. This is referred to as a primary meter and may be installed either in the Producer-owned switchgear, indoor or outdoor, or on a Producer-owned pole, outdoor. Such installations require coordination between the Producer and Vectren regarding accuracy class, technical details and locations.

| | | |
|---|---|--------------------------------|
|  | ENERGY DELIVERY INTERCONNECTION GUIDELINES FOR CUSTOMER-OWNED GENERATION (VEC) | Revision Number 3 |
| VEC-006 Energy Delivery Interconnection Guidelines for Customer-Owned Generation | | |

For metering option “A”, "generation" metering shall be connected so that energy from the generator is measured, and energy to the generator, from the Vectren electric system, is measured. For metering option "B", "load" metering shall be measured in addition to “generation” metering.

6.5 Generation 1 MW and Above

Metering options “A” or “B” shall be applied for this category as shown in Figure 10.4. In general, these meters shall require dedicated instrument transformers and the installation requirements shall conform to the Vectren Electric Service Manual.

If the nominal voltage of the metered circuit exceeds 480 volts, a transformer type primary meter installation, using both current and voltage transformers is required, regardless of the load current. This is referred to as a primary meter and may be installed either in Producer-owned switchgear, indoor or outdoor, or on a Producer-owned pole, outdoor. Such installations require coordination between the Producer and Vectren regarding accuracy class, technical details and locations.

For metering option “A”, "generation" metering shall be connected so that energy from the generator is measured, and energy to the generator, from the Vectren electric system, is measured. For metering option "B", "load" metering shall be measured in addition to “generation” metering. For metering option "B", the Producer shall consult Vectren regarding metering requirements.

The generating system in this category shall provide telemetering to Vectren’s designated operating center (and the MISO if applicable) for continuous kilowatt, kilovar, and hourly generation values in kilowatt-hours.

| | | |
|---|---|----------------------------------|
|  | ENERGY DELIVERY INTERCONNECTION GUIDELINES FOR CUSTOMER-OWNED GENERATION (VEC) | Revision Number 3 |
| VEC-006 Energy Delivery Interconnection Guidelines for Customer-Owned Generation | | |

7 Protective Relaying Requirements

7.1 Protection Classes

Vectren has established seven different classes of protective relaying for interconnected customer-owned generation. These classes are:

1. 0 - 10 kW
2. 10 kW - 100 kW
3. 100 kW - 1 MW
4. 1 MW - 10 MW
5. Over 10 MW
6. Hot Transfer Standby Generation
7. Demand Reduction Generation

The protective relaying schemes are shown in Figure 10-1 through Figure 10-5. The installation must be permanently wired within a suitable load center and a lockable disconnect switch shall be provided which is readily accessible to Vectren personnel at all times. This switch shall be located at the meter unless an alternate location is readily accessible and easily identifiable. The alternate location must be approved by Vectren.

The Producer's protective relaying schemes must be coordinated with Vectren's schemes.

Relay protection classes are based upon the generator or inverter nameplate ratings. When multiple generators are connected to the Vectren electric system through a single service point, the class shall be determined by the sum of the generator ratings.

These classes have been established for convenience and are based on circuits with normal load density. The final decision as to the requirements for each installation will be made depending on concerns such as: the Producer's generating system's load magnitude, the magnitude of other loads connected to that circuit, available short circuit contribution, source substation size and line conductor size. Vectren cost for installing, maintaining, and/or rearranging such relaying equipment shall be borne by the Producer.

| | | |
|---|---|----------------------------------|
|  | ENERGY DELIVERY INTERCONNECTION GUIDELINES FOR CUSTOMER-OWNED GENERATION (VEC) | Revision Number 3 |
| VEC-006 Energy Delivery Interconnection Guidelines for Customer-Owned Generation | | |

7.2 Generation 10 kW & Under

All installations in this class shall require a site review by Vectren personnel. Those installations that are a standard package will be reviewed once. No further package review will be required for additional installations provided no changes in configuration or equipment are made to the package. Installations that are not a standard package shall be reviewed individually.

7.3 Generation Over 10 kW to Less Than 100 kW

All installations in this class shall require a site review by Vectren personnel. Those installations that are a standard package shall be reviewed once. No further package review will be required for additional installations provided no changes in configuration or equipment are made to the package. Installations that are not a standard package shall be reviewed individually.

The protective relaying schemes are shown in Figure 10.2. The larger installations in this class shall use industrial grade relays or utility grade relays. The larger installations may vary somewhat from the layout shown in Figure 10. 2. Some variation in the specifics, but not of the intent of the requirements, will be allowed. All variations shall be approved by Vectren.

7.4 Generation 100 kW to Less Than 1 MW

All installations in this class shall require a full protective relaying and site review by Vectren personnel. The protective relaying schemes are shown in Figure 10.3. For some of the larger installations, the transformer and associated equipment may be owned by the Producer instead of Vectren. Utility grade protective relays, such as those normally found in utility switchgear and utility grade equipment shall be required. The following manufacturers, as well as some others, produce utility grade protective relays: Schweitzer Engineering Laboratories, General Electric, ABB Power T & D Company, Inc. and Basler Electric.

7.5 Generation 1 MW to Less Than 10 MW

All installations in this class shall require a full protective relaying and site review by Vectren personnel. The protective relaying schemes are shown in Figure 10.4. For some of the larger installations, the transformer and associated equipment may be owned by the Producer instead of Vectren. Utility grade protective relays, such as those normally found in utility switchgear and utility grade equipment shall be

| | | |
|---|---|--------------------------------|
|  | ENERGY DELIVERY INTERCONNECTION GUIDELINES FOR CUSTOMER-OWNED GENERATION (VEC) | Revision Number 3 |
| VEC-006 Energy Delivery Interconnection Guidelines for Customer-Owned Generation | | |

required. The following manufacturers, as well as some others, produce utility grade protective relays: Schweitzer Engineering Laboratories, General Electric, ABB Power T & D Company, and Basler Electric.

Many rural systems will not accept this class of generation and, as such, shall be treated in the same manner as the over 10 MW class. Most circuits will most likely require modifications to be compatible with this class of installation.

7.6 Generation Over 10 MW

In general, the Vectren distribution system is designed to handle load and generation up to 10 MW. Generation in excess of 10 MW shall be served from the transmission system. Each installation is unique so that no general requirements are possible. Each installation shall be discussed and reviewed by Vectren personnel on an individual basis. Vectren shall be contacted, by the Producer, to determine the feasibility of any proposal, due to the restrictive nature and cost of interconnection to the Vectren electric system.

7.7 Battery Power & DC Fusing

1. A battery power system may be required to provide DC for powering control systems, breaker control, and powering protective relays if determined to be needed for proper system protection by Vectren. The cost of this system is the responsibility of the Producer.

2. Adequate protection for the loss of a DC fuse shall be provided. Figure 10.6 illustrates an example of a DC fusing scheme utilizing a loss of potential relay to trip the breaker. A loss of potential relaying scheme shall be required when there is no relaying redundancy. In installations where relaying redundancy exists, the DC fusing scheme shall prevent common mode failure of the sensing, tripping and interruption equipment. The entire tripping scheme shall not become disabled by a single DC fuse operation. Relay redundancy can be achieved through a combination of relays or an exact duplication of relays.

| | | |
|---|---|--------------------------------|
|  | ENERGY DELIVERY INTERCONNECTION GUIDELINES FOR CUSTOMER-OWNED GENERATION (VEC) | Revision Number 3 |
| VEC-006 Energy Delivery Interconnection Guidelines for Customer-Owned Generation | | |

8 Demonstrations/Inspections of Protective Devices

8.1 General

The Producer shall demonstrate to Vectren personnel the correct operation of all protective devices. Vectren shall not be responsible for performing these demonstrations. The Producer shall provide qualified personnel to perform these demonstrations/inspections.

Demonstrations/inspections shall be performed on all new equipment and modified equipment, and on existing equipment as circumstances warrant or when requested by Vectren.

These demonstrations shall be divided into three sections: Calibration, Trip Checks and On-Line Testing. The Calibration section shall demonstrate that agreed upon settings, between the Producer and Vectren, are used on each of the relays required by Vectren. This section also demonstrates that the relays are functional and calibrated to their manufacturer's tolerances. The Trip Checks section shall demonstrate that each of the required relays operate correctly and that their interlocks operate correctly. The On-Line Tests section shall demonstrate the expected operation of relays and interlocks specific to the interconnection interface.

The following Calibration, Trip Checks and On-Line Testing sections are intended to serve as guidelines. These demonstrations are designed to be non-destructive; however, Vectren shall not be responsible for any equipment damage or injury resulting from these demonstrations. It shall be the Producer's responsibility to demonstrate operation of all protective devices in a safe manner. These demonstrations should not adversely affect the generator or any equipment associated with the interconnection. Vectren costs for witnessing these demonstrations shall be borne by the Producer.

8.2 Calibration

Proper testing and verification of CTs and VTs and relay settings shall be demonstrated to Vectren personnel in the following manner:

1. Four tests shall be performed for CT verification and are as follows:
 - a. Ratio check shall be performed according to the [ANSI/IEEE C57.13.1](#), Section 6.

| | | |
|---|---|--------------------------------|
|  | ENERGY DELIVERY INTERCONNECTION GUIDELINES FOR CUSTOMER-OWNED GENERATION (VEC) | Revision Number 3 |
| VEC-006 Energy Delivery Interconnection Guidelines for Customer-Owned Generation | | |

- b. Polarity check shall be performed according to the [ANSI/IEEE C57.13.1](#), Section 7.
 - c. Excitation Test, Saturation Test, reports from the manufacturer or in lieu of the reports, shall be performed according to the [ANSI/IEEE C57.13.1](#), Section 9.
 - d. Insulation Resistance Test, meggering, shall be performed according to the [ANSI/IEEE C57.13.1](#), Section 5.
2. Two tests shall be performed for VT verification and are as follows:
 - a. Ratio Check shall be performed in a like manner as described under "Ratio Tests" in the [ANSI/IEEE C57.13.1](#), Section 6, using voltage method.
 - b. Polarity Check shall be performed in a like manner as described under "Polarity Checks" in the [ANSI/IEEE C57.13.1](#), using either DC or AC voltage tests under Section 7.1 and 7.2.
 3. Relays shall be tested as follows:
 - a. Tested according to their manufacturer's acceptance specifications.
 - b. Tested at on-line setting values to verify calibration. If possible, this can be completed as part of the relay acceptance test.

All testing and calibration of CTs, VTs and relays shall be performed with test equipment of current calibration according to manufacturer's calibration specifications and intervals. Proof of test equipment calibration must be produced upon request from Vectren prior to relay calibration. All systems over 1 MW must have Vectren's Electric Test Department personnel witness the synchronizing relay and sync-check relay calibration and operation.

8.3 Trip Checks

1. All required relays shall be functionally operated to demonstrate correct operation. Tests can be performed off-line if possible. Tests that cannot be performed off-line shall be demonstrated to functionally operate on-line. Trip outputs from the relay may be either by manually operating all appropriate contacts, dictated by design, or by injecting an electrical signal to cause a trip output. If an 86 device is used with a blocking relay, then the relay(s) shall be

| | | |
|---|---|----------------------------------|
|  | ENERGY DELIVERY INTERCONNECTION GUIDELINES FOR CUSTOMER-OWNED GENERATION (VEC) | Revision Number 3 |
| VEC-006 Energy Delivery Interconnection Guidelines for Customer-Owned Generation | | |

tripped a minimum of one time through the entire scheme. All other trips may then be performed in such a manner so only the 86 device trips.

2. Verify that breaker(s) cannot be manually or automatically closed with the trip relay in the latched or trip position.
3. Demonstrate that the synchronism check and synchronizing relays wiring is correct and interlocks operate correctly.
4. Demonstrate that interlocks between the generator and Vectren breaker(s) operate properly; i.e., the Producer cannot re-energize a de-energized the Vectren electric system supply and can only tie to an energized the Vectren electric system supply via a synchronizing device.
5. Demonstrate that the breaker can not be closed either manually or automatically without resetting the 86 device.
6. For inverters with anti-islanding protection, proper operation shall be demonstrated.

8.4 On-Line Tests

Items "1" through "6" shall be performed with the generator breaker racked out in the test position and the line breaker closed, energizing the transformer.

1. Undervoltage Relay - Device 27: Prior to putting the generator on-line, lift the potential to the relay. Expected result is the operation of Device 27 after the specified time delay.
2. Ground Overvoltage Relay - Device 59N: Verify proper voltage present at relay input (relay may not be used on smaller generation units).
3. Frequency Relay - Device 81 O/U: Verify proper voltage present at relay input.
4. Phase-Sequence and Voltage Balance Relay - Device 47/60 or 47/27: Interchange two of the potential inputs to this relay to simulate a negative-phase sequence condition. Expected result is the operation of this relay after the specified time delay. Also, lift one potential lead and observe relay trip output. Once testing of this device is

| | | |
|---|---|--------------------------------|
|  | ENERGY DELIVERY INTERCONNECTION GUIDELINES FOR CUSTOMER-OWNED GENERATION (VEC) | Revision Number 3 |
| VEC-006 Energy Delivery Interconnection Guidelines for Customer-Owned Generation | | |

completed, restore the potential input connections to their original polarities.

5. Synchronous generators - Phase out and check the rotation of the primary potential on both incoming and running sides of the generator breaker with the generator running unloaded, i.e. between the generator and the Vectren electric system. While performing the phase out and rotation check, test phasing and rotation across the open generator breaker using synchroscope and voltmeter for VT secondary verification. Verify a single sync path through the sync-select switch on multi-unit operations. Verify correct phase and polarity of VT inputs to sync-check relay. Verify proper synchronizing potential sources.

6. Induction generators - Allow the prime mover to rotate the generator with generator breaker open. Then, with the prime mover removed, briefly "motor" the generator by closing the generator breaker. Expected result is the same direction of rotation. Upon completion of "4.", with the generator breaker still racked out in the test position, verify that the synchronizer/sync-check or speed relays give a breaker close output signal at the appropriate synchronized conditions, proper voltage magnitude match, phase rotation, phase angle match, and proper slip rate.

7. Flicker and Harmonics test - With the generator breaker open, close the Vectren line breaker, start up the generator and synchronize the generator to the Vectren-energized transformer. Verify that acceptable minimal flicker of room lights occurs at the close of the generator breaker and that the generator runs in a stable unloaded condition in parallel with the Vectren electric system. Synchronizing should normally take place while the synch-scope is moving in the "fast" direction, clockwise. An oscillograph shall be used to verify proper breaker pole alignment and the absence of harmonics.

8. Directional Power Relay – Device 32: With the generator on-line, cause the generator to motor. Expected result is the operation of 32 device after the specified time delay. An alternate test is to phase check, under load, at the directional relay, with a phase angle meter.

| | | |
|---|---|--------------------------------|
|  | ENERGY DELIVERY INTERCONNECTION GUIDELINES FOR CUSTOMER-OWNED GENERATION (VEC) | Revision Number 3 |
| VEC-006 Energy Delivery Interconnection Guidelines for Customer-Owned Generation | | |

9. Voltage Supervised or Directional Overcurrent Relay - Device 51V:
With the generator on-line, run the generator above zero voltage current pick-up level with voltage applied; lift the potential. Expected result is the operation of 51V device after the specified time delay.

10. Power Factor Controller Test shall be done with a plant load that can be interrupted during test procedures:
 - a. With the generator off-line, measure the power factor of the full house power kW load. The measured value will usually be lagging, not unity.
 - b. Set the generator power factor controller to a more leading pf, usually unity. This creates a var mismatch between the load and generator. Also, block the 81 O/U relay.
 - c. Bring the generator on-line. The station service load shall be served by the generator.
 - d. Match the generator kW to the house power load.
 - e. Trip the Vectren line breaker.
 - f. The generator should trip on low voltage, due to power factor mismatch, by means of the undervoltage relay. An oscillograph, provided by the Producer, will monitor all three-phase currents, bus voltages, neutral current or generator neutral current, and a contact off the generator and Vectren line breakers.

11. A demonstration of compliance with contracted power factor shall be performed for induction generators and inverters.
 - a. VAR Capacity Tests: For generators which possess adjustable voltage regulation, a demonstration that the generator is capable of operation at a 90% leading and lagging power factor shall be performed. These tests shall be conducted at 25%, 50%, 75%, and 100% of rated generator load. The capacity tests into the lead can be limited or waived because of operational limitations due to manufacturer's design criteria or stator end turn heating concerns.

| | | |
|---|---|--------------------------------|
|  | ENERGY DELIVERY INTERCONNECTION GUIDELINES FOR CUSTOMER-OWNED GENERATION (VEC) | Revision Number 3 |
| VEC-006 Energy Delivery Interconnection Guidelines for Customer-Owned Generation | | |

9 Periodic Demonstrations/Inspections of Protective Devices

9.1 Maintenance

The Producer shall maintain its equipment in good order. Vectren reserves the right to inspect the Producer's generating system, at the Producer's expense, whenever it appears that the generating system is operating in a manner detrimental to the integrity of the Vectren electric system. The Producer shall annually perform functional testing of all breakers, relays, and transformers. Installations must have a full relay calibration check performed every three years and certified test reports shall be forwarded to Vectren.

If the Producer's generating system is interconnected directly to the Vectren electric system, or if the interconnection to the Vectren electric system could adversely affect the integrity of the Vectren electric system, because of abnormal operation of the Producer's generating equipment, the Producer shall demonstrate the proper testing of the interface protective devices to Vectren. Otherwise, interface protective devices shall be tested and may or may not have to be demonstrated. The Producer shall provide qualified personnel to perform these demonstrations. Vectren costs for this demonstration shall be borne by the Producer.

Maintenance of the Producer's generating system shall be coordinated with Vectren and, if required, with the MISO. The Producer shall schedule a minimum of one year in advance with Vectren (and MISO if applicable) all planned maintenance which would impact the output of the Producer's facilities. The Producer shall contact the Vectren TSO as soon as practical should an unscheduled outage be needed or if one should occur.

9.2 Annual Demonstrations/Inspections

It shall be the Producer's responsibility to conduct an annual demonstration/inspection of interconnection trip schemes and generator synchronization. The Producer shall provide qualified personnel to perform these demonstrations. These demonstrations are designed to be non-destructive, and it shall be the Producer's responsibility to conduct these demonstrations in a safe manner. Vectren shall not be responsible for any equipment damage or injury resulting from these demonstrations. These demonstrations should not adversely affect the generator or any equipment associated with the interconnection.

| | | |
|---|---|--------------------------------|
|  | ENERGY DELIVERY INTERCONNECTION GUIDELINES FOR CUSTOMER-OWNED GENERATION (VEC) | Revision Number 3 |
| VEC-006 Energy Delivery Interconnection Guidelines for Customer-Owned Generation | | |

Vectren costs for witnessing these demonstrations shall be borne by the Producer. These annual demonstrations shall consist of the following:

1. All interconnection trip schemes and interlocks shall be demonstrated annually for proper operation. All interface protective devices shall be trip tested in such a manner so that a trip signal originates from the protecting device. The trip command can be simulated by closing a mechanical contact, or relay device secondary circuit injection of voltage, current, or frequency to cause a trip, or by the removal or change of a protective device's sensing circuit input, without lifting wiring, to cause a trip.

2. Anti-islanding protection shall be tested annually for generators rated 100 kW and under.

If an 86 device is used with a blocking relay, then the relay(s) shall be tripped a minimum of one time through the entire scheme. All other trips may then be performed in such a manner so that only the 86 device trips.

Synchronizing shall be demonstrated annually in automatic and manual mode, if applicable. With the breaker in the test position, verify that close is blocked for an out-of-phase condition, allows close in an in-phase condition and blocks close on a dead bus condition.

9.3 Three-Year Demonstrations/Inspections

In addition to the annual demonstrations/inspections, it shall be the Producer's responsibility to conduct three-year demonstrations of relay operation and generator VAR capacity performance. The Producer shall provide qualified personnel to perform these demonstrations. These demonstrations are designed to be non-destructive, and it shall be the Producer's responsibility to conduct these demonstrations in a safe manner. Vectren shall not be responsible for any equipment damage or injury resulting from these demonstrations. These demonstrations should not adversely affect the generator or any equipment associated with the interconnection. Vectren costs for witnessing these demonstrations shall be borne by the Producer. These annual demonstrations shall consist of the following:

1. Relays are functional and calibrated at approved settings and within their manufacturer's tolerances. Refer to manufacturer's literature for test procedures.

| | | |
|---|---|--------------------------------|
|  | ENERGY DELIVERY INTERCONNECTION GUIDELINES FOR CUSTOMER-OWNED GENERATION (VEC) | Revision Number 3 |
| VEC-006 Energy Delivery Interconnection Guidelines for Customer-Owned Generation | | |

2. The VAR capacity test shall be demonstrated on generators that have adjustable voltage regulation. Operation at 90% leading and lagging power factor shall be performed. Tests shall be conducted at 25%, 50%, 75%, and 100% of rated generator output. The capacity tests into the lead can be limited or waived because of operational limitations due to manufacturer's design criteria or stator end turn heating concerns.

9.4 Design Changes After Commercial Operation

Design changes that could jeopardize the integrity of the interconnection protection and synchronizing schemes shall be reviewed and approved by Vectren, at the Producer's expense. Demonstrations/inspections of relay calibration, trip tests and on-line testing may be required depending on the extent of the design change. Changes to the Vectren electric system can be necessary and may be extensive. The cost of these changes shall be borne by the Producer.

Setting changes of any interconnection protection or synchronizing device, or any "Field Modification" or "As Built" protection and synchronizing schematics associated with any interconnection device shall be reviewed and approved by Vectren, at the Producer's expense.

10 Figures

10.1 Relaying and Metering 10 kW & Under

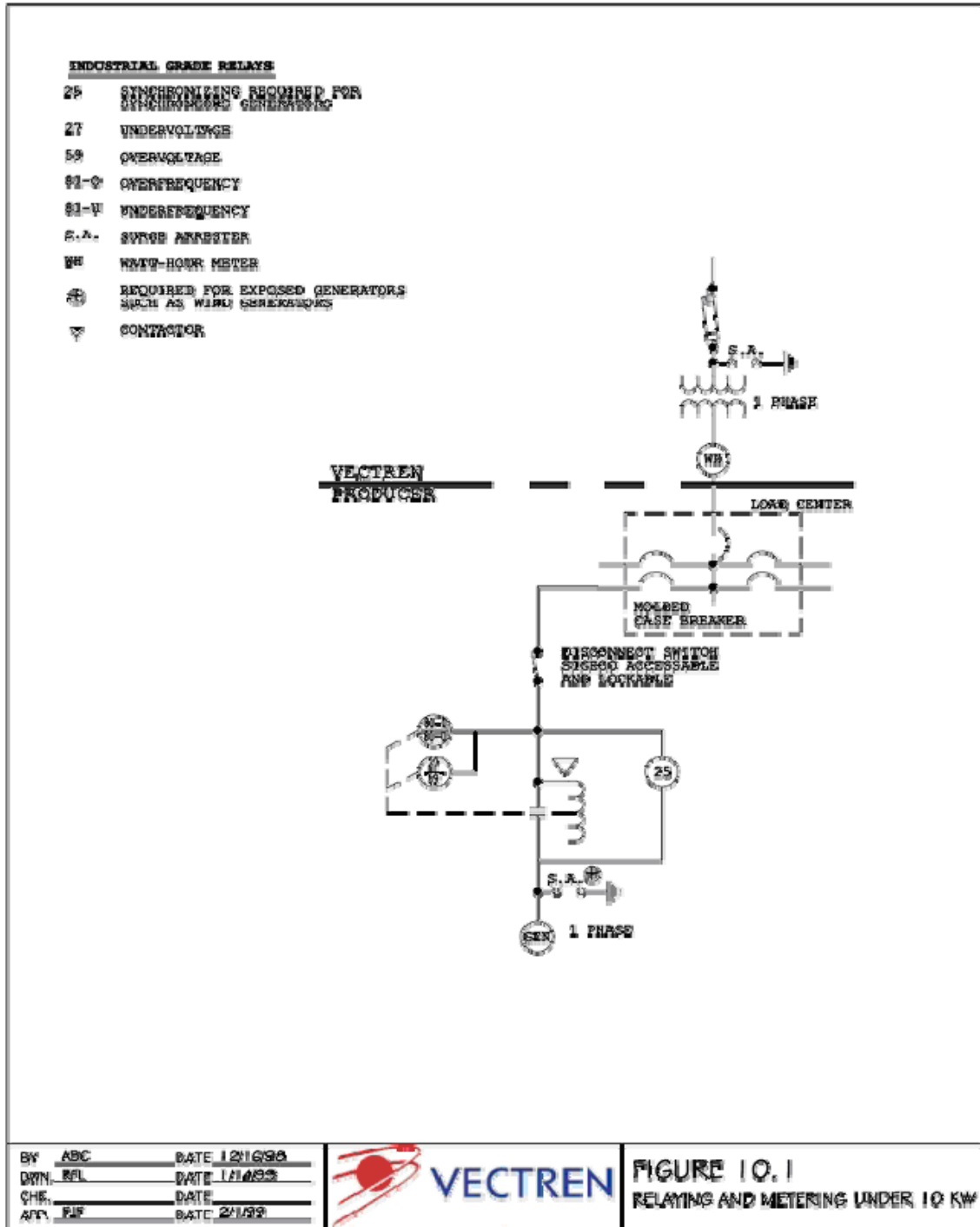

10.3 Relaying and Metering From 100 kW to Less Than 1 MW

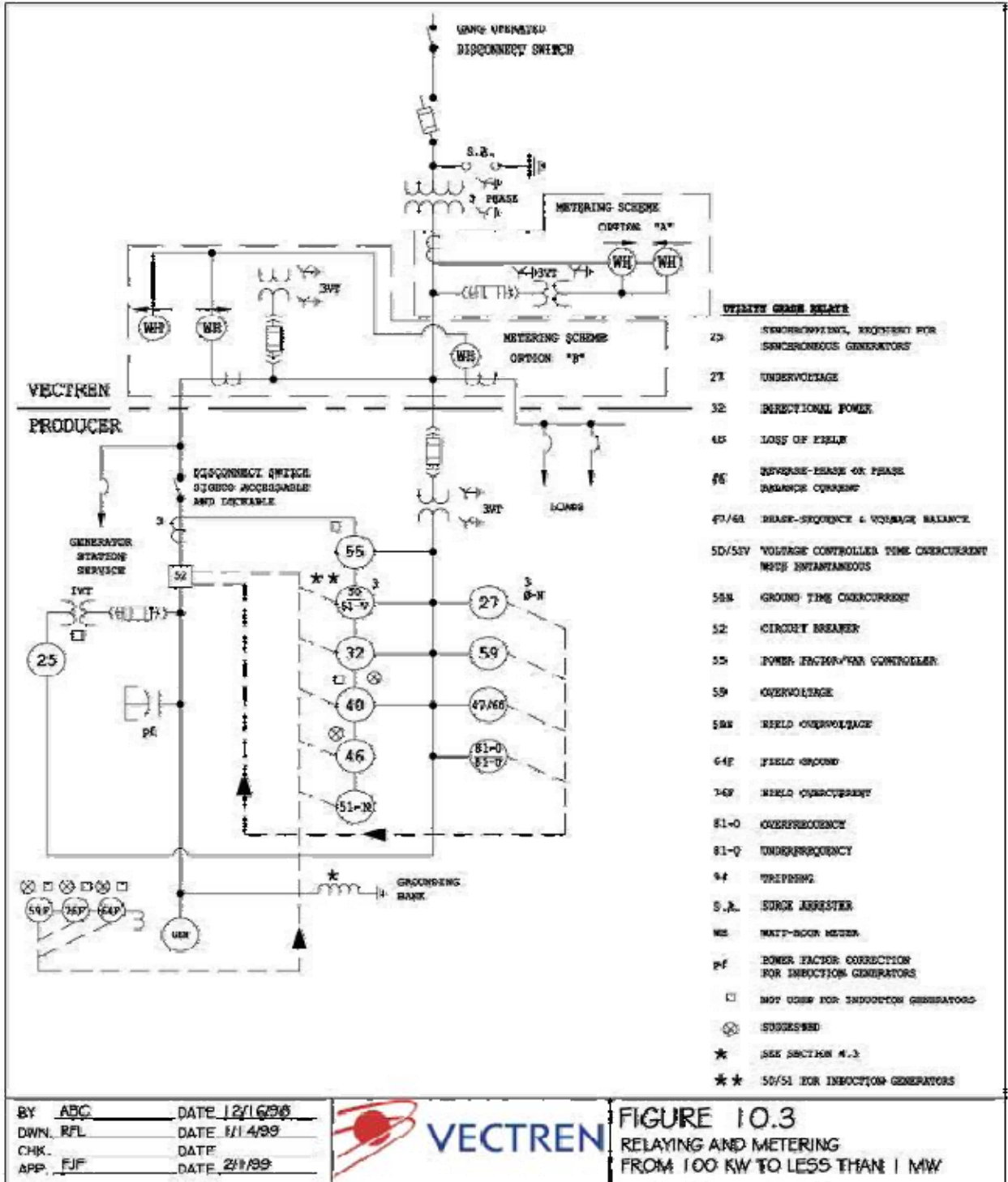

10.4 Relaying and Metering From 1 MW to Less Than 10 MW

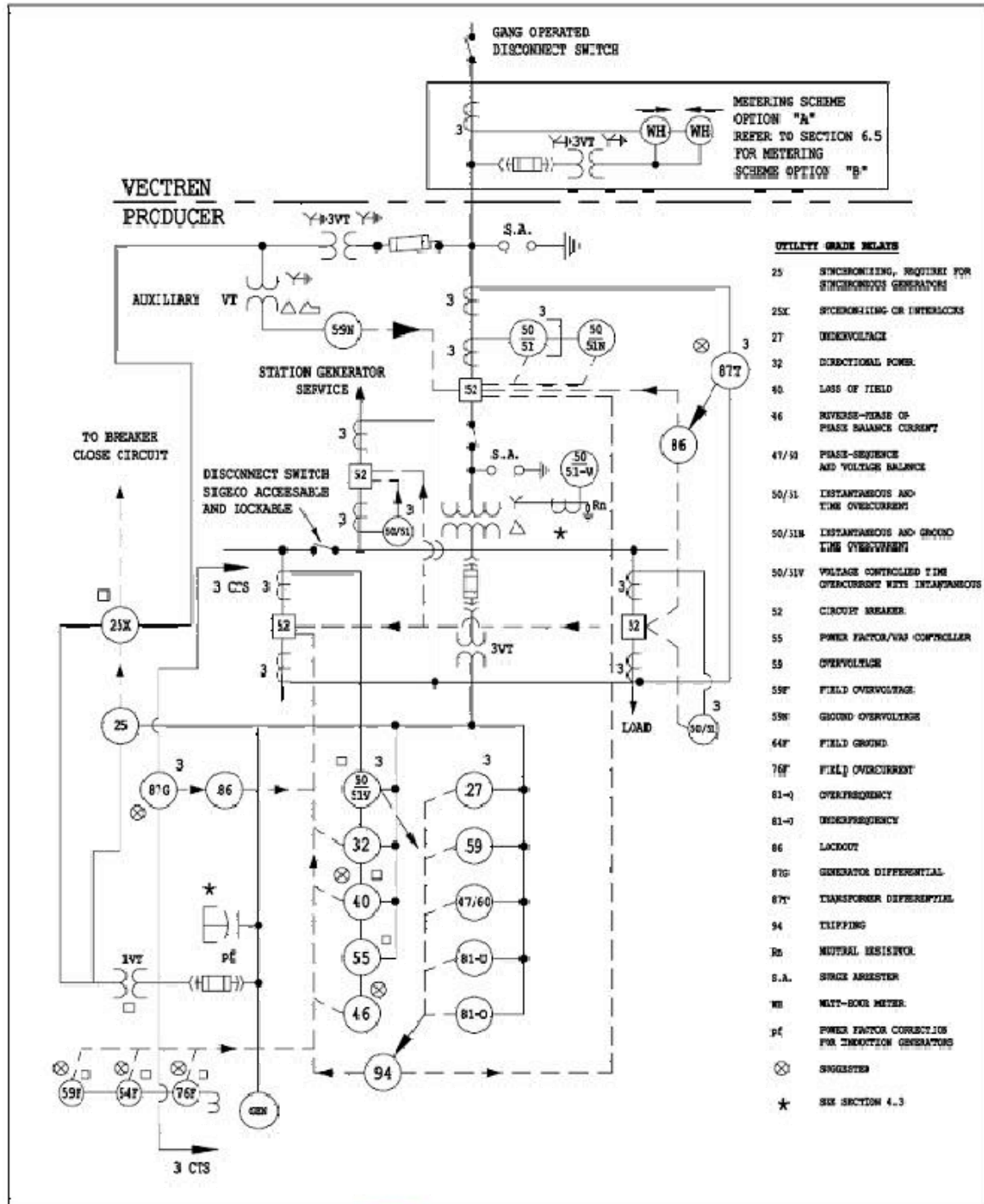

- UTILITY GRADE RELAYS**
- 25 SYNCHRONIZING, REQUIRED FOR SYNCHRONOUS GENERATORS
 - 25X SYNCHRONIZING OR INTERLOCKS
 - 27 UNDERVOLTAGE
 - 32 DIRECTIONAL POWER
 - 40 LOSS OF FIELD
 - 46 REVERSE-PHASE OR PHASE BALANCE CURRENT
 - 47/50 PHASE-SEQUENCE AND VOLTAGE BALANCE
 - 50/51 INSTANTANEOUS AND TIME OVERCURRENT
 - 50/51W INSTANTANEOUS AND GROUND TIME OVERCURRENT
 - 50/51V VOLTAGE CONTROLLED TIME OVERCURRENT WITH INSTANTANEOUS
 - 52 CIRCUIT BREAKER
 - 55 POWER FACTOR/WAS CONTROLLER
 - 59 OVERVOLTAGE
 - 59F FIELD OVERVOLTAGE
 - 59G GROUND OVERVOLTAGE
 - 44F FIELD GROUND
 - 76F FIELD OVERCURRENT
 - 81-Q OVERFREQUENCY
 - 81-U UNDERFREQUENCY
 - 86 LOCKOUT
 - 87G GENERATOR DIFFERENTIAL
 - 87T TRANSFORMER DIFFERENTIAL
 - 94 TRIPPING
 - Rn NEUTRAL RESISTOR
 - S.A. SURGE ARRESTER
 - WH WATT-HOUR METER
 - WT POWER FACTOR CORRECTIVE FOR INDUCTION GENERATORS
 - ⊗ SUGGESTED
 - ★ SEE SECTION 4.3

| | |
|----------|---------------|
| BY ABC | DATE 12/21/98 |
| DWN. RFL | DATE 1/14/99 |
| CHK. | DATE |
| APP. FJF | DATE 2/1/99 |



FIGURE 10.4
RELAYING AND METERING
FROM 1 MW TO LESS THAN 10 MW

10.6 DC Fusing

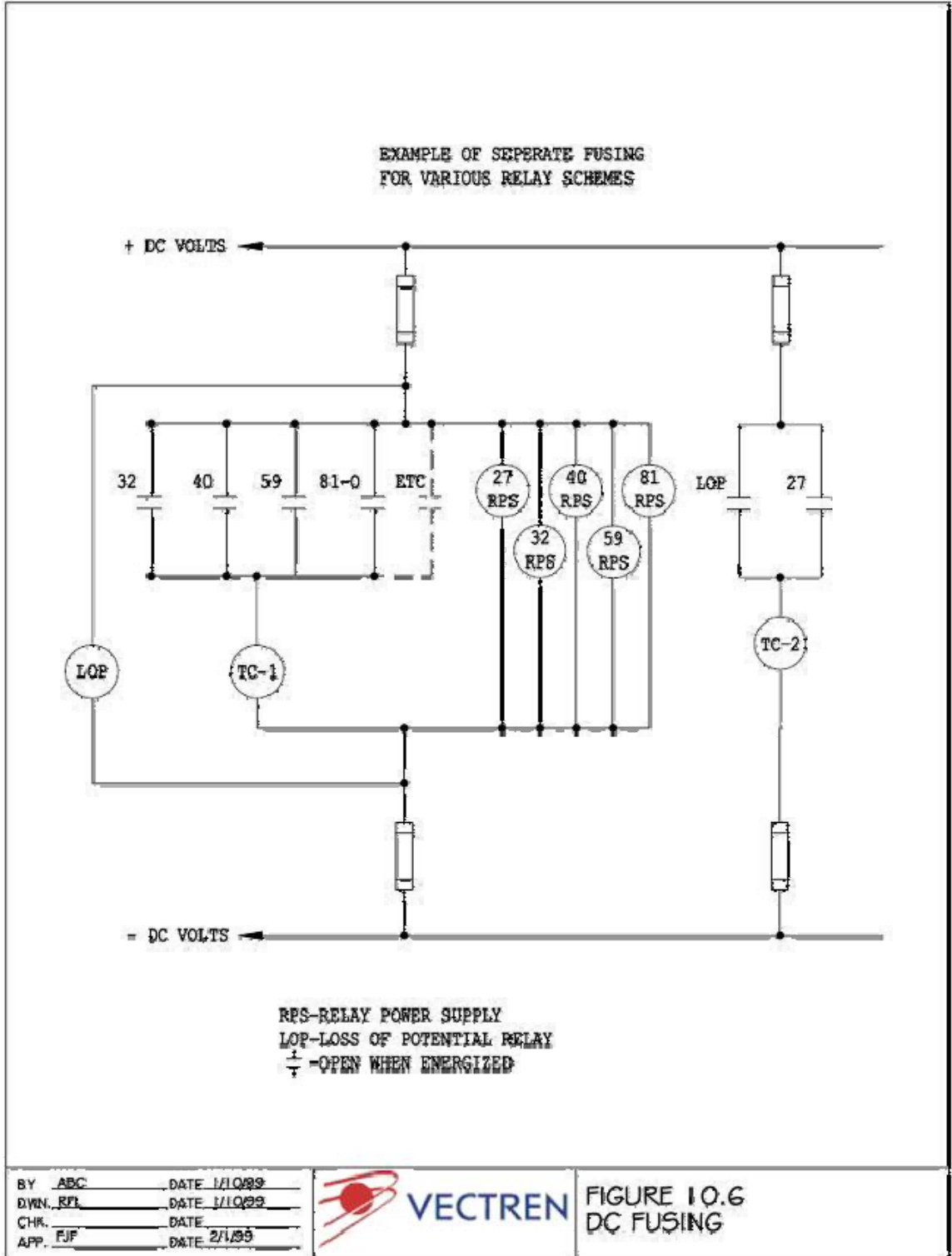

11 Appendix 1

Induction Generator Characteristics Survey

Name of Project _____

Manufacture _____

Type _____

Model _____

Number of Phases _____

Rated KW Output _____

Rated KVA Output _____

Rated Voltage (line to line) _____

Rated Current _____

Maximum KW Output (prime mover & Generator) _____

Power Factor or Rated Load (KVAR):

At maximum KW Output _____

At 100 % of Rated Output _____

At 75 % of Rated Output _____

At 50 % of Rated Output _____

At 25 % of Rated Output _____

Connection (wye or delta) _____

Is the wye point grounded? _____

Impedance in ground connection _____

Rotor Resistance (R_r) _____

Rotor Reactance (X_r) _____

Stator Resistance (R_s) _____

Stator Reactance (X_s) _____

Magnetizing Branch Reactance (X_m) _____

Short Circuit Time Constant (T) _____

Slip at Rated Output (s) _____

Synchronous Speed _____

Inertia of Combined Machine _____

12 Appendix 2

Synchronous Generator Characteristics Survey

Name of Project _____

Manufacture _____

Type _____
Model _____
Number of Phases _____
Rated KW Output _____
Rated KVA Output _____
Rated Voltage (line to line) _____
Rated Current _____
Rated Power Factor: leading _____
Rated Power Factor: lagging _____
Maximum KW Output (prime mover & Generator) _____
Maximum KW Output (prime mover & Generator) _____

With generator at this maximum KW,
What is the maximum leading power factor?

What is the maximum lagging power factor? _____

Connection (wye or delta) _____

Is the wye point grounded? _____
Impedance in ground connection _____
Synchronous Reactance (X_d) _____
Transient Reactance (X'_d) _____
Sub-Transient Reactance (X''_d) _____
Negative-Sequence Reactance (X_2) _____
Zero-Sequence Reactance (X_0) _____
Transient Time Constant (T'_d) _____
Sub-Transient Time Constant (T''_d) _____
Inertia Constant (W_r^2) _____
Synchronous Speed _____

| | | |
|--|---|----------------------------------|
|  VECTREN | ENERGY DELIVERY INTERCONNECTION GUIDELINES FOR CUSTOMER-OWNED GENERATION (VEC) | Revision Number 3 |
| VEC-006 Energy Delivery Interconnection Guidelines for Customer-Owned Generation | | |

13 Cross References

Documents Cross Reference Table

| Document Name | References To Document Name |
|--|---|
| VEC-007 Requirements for Transmission or End-User Facilities Interconnection to the Vectren Electric Transmission System | Section 1.3 – Requirements for Interconnection |
| IEEE Std. 519 | Section 3.2 – Vectren Electric System Integrity, Harmonic Distortion Section 5.7 - Generating System Design Requirements, Inverter Systems |
| Vectren Electric Service Manual | Section 6 – Metering Requirements |
| ANSI/IEEE C57.13.1, Sections 5,6,7,7.1,7.2,9 | Section 8.2 – Demonstrations/Inspections of Protective Devices, Calibration |